



L-3000 Series

High Performance Liquid Chromatography Systems

Company Profile

Founded in 1998, **RIGOL** is an ISO9001:2000 Quality Management System and ISO14001:2004 Environmental Management System Certified company, an emerging T&M leader and a technology innovator in Chemical Analysis and Electronic Measurement. **RIGOL's** premium line of products includes HPLC and UV-Vis Spectrophotometers, and General Purpose, RF Communication Electronic Instruments, which help the engineers, researchers, educators to address their measurement challenges in confidence with better affordability than ever before.



RIGOL is headquartered in Beijing, China, with the branch offices in Cleveland, OH, United States and Munich, Germany. The company's 400 employees and more than 150 distributors or representatives offer products and services in over 60 countries/regions on six continents. More information about **RIGOL** is available at hplc.rigol.com.





L-3000 HPLC System

Excellent Performance >>>>

- 9000PSI working pressure
- 2.5AU Linearity range
- 100Hz Sampling rate
- Rapid analysis achievable
- More efficient, less consume

Flexible Configuration >>>>

- Modularized design
- Multi-channel pumps
- Alternative injection modes
- Various detectors
- Custom combination

Professional Service >>>>

- Instrument installation & various training courses
- Application & regulatory compliance service
- Remote diagnose & prompt response
- Preventive maintenance & service plans
- Proactive and comprehensive service





***Your professional manufacturing supplier
of Chromatography/Spectrum
instruments, plus delicate
service & application solution.***



Selection Reference



	Module&Model	Isocratic Manual HPLC System	Binary Manual HPLC System	Binary Auto -sampling HPLC system	Quaternary Manual HPLC System
Solvent Organizer	L-3100	●			
	L-3120		●	●	
Pump	L-3210	●			
	L-3220		●	●	
	L-3245				●
Sampler	7725i	●	●		●
	L-3320			●	
Column Oven	L-3400	○	○	○	○
Detector	L-3500	○	○	○	○
	L-3520	○	○	○	○
	L-3535	○	○	○	○
	L-3560	○	○	○	○

● Must ○ Optional ○ Multi-choice



Typical Configuration

Quaternary Auto-sampling HPLC System	Remarks
	Seal wash, without degasser
	Seal wash, 2 channels degasser
	Isocratic Pump
	Binary Pump
●	Quaternary Pump with integrated degasser
	Manual Injector
●	Autosampler
○	Semiconductor temp. control
◎	UV-VIS Detector
◎	DAD
◎	ELSD
◎	RID



Isocratic System with Manual Injector

This isocratic system could deliver one type of mobile phase. By combing the best performance cost ratio, system stability and maintenance simplicity, this system is an ideal solution for routine QA/QC analysis and GPC/SEC application. It can also be simply upgraded into gradient system with autosampler to boost your productivity.



Quaternary System with Autosampler

Quaternary system possesses the advantage of great flexibility, and it can further be automatized by combing our autosampler. This combination could fulfil the complex requirements from pharmacy, environmental, food safety, petrochemical engineering, agricultural & farming fields. With the control from RIGOL Chromatography workstation, it realized full automatic analysis, report, system flush, shut down and then raised up the efficiency.



Binary System with Autosampler

With excellent gradient precision & optimized delay volume, this binary system plus autosampler is ideal for complex gradient application or be used in combination with mass spectrometry. With the convenience of autosampler and various detector, the user could easily get more data.

L-3200 Series High Pressure Pump



Performance Highlights

High Pressure Limit

L-3200 serial high pressure pump could reach 9000psi (62Mpa) working pressure with the flow rate up to 10mL/min. This high performance extend the application field from normal HPLC to Fast HPLC. With the help of 100Hz detecting and high precision sampling, you can take advantage of small piratical size column and reduce solvent consumption.

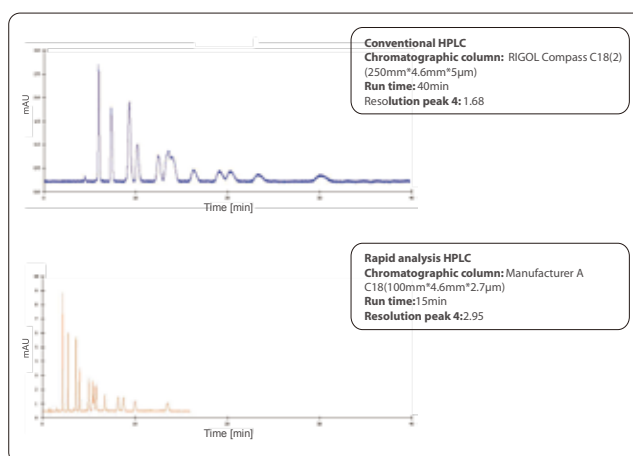
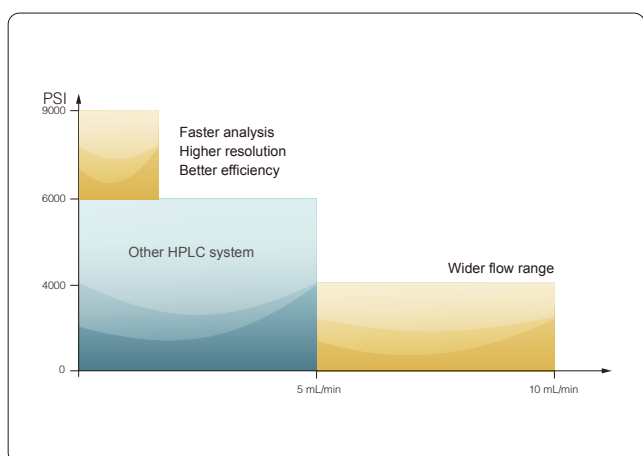

Precise Flow Rate & Gradient

L-3200 serial high pressure injection pump could monitor the pressure status by its digital signal processor and adjust the motor operation status based on working parameters and solvent type. This real time feedback mechanism plus the high performance proportional valve realized the steady flow output as well as precise .

Stable Pressure

L-3200 serial high pressure pump's pressure pulsation could be controlled under 10psi with best qualitative repeatability based on it state of art patent design, precise engineering and strict quality control.

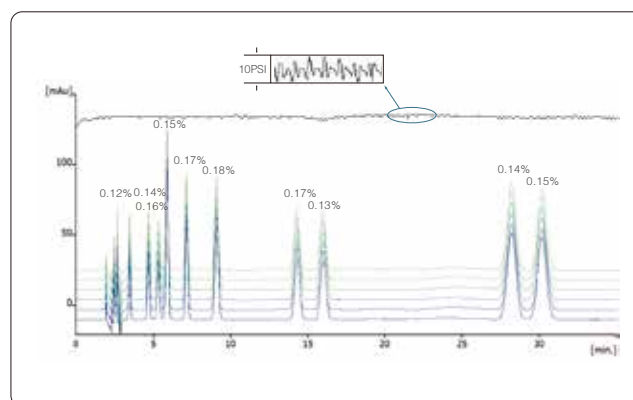
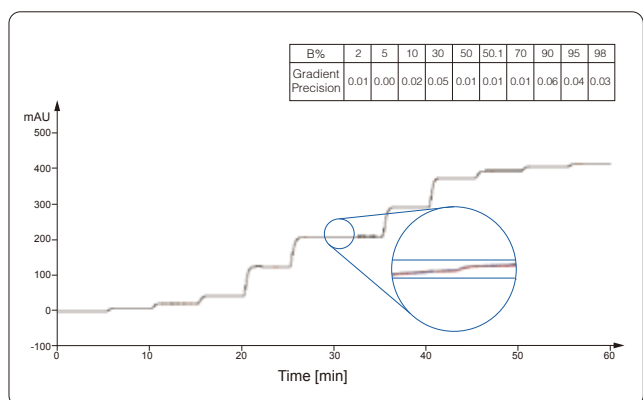

Column: back pressure tube (1000PSI)
Mobile Phase A: 1% isopropanol aqueous solution
Mobile Phase B: 0.2% acetone/1% isopropanol aqueous solution
Flow rate: 1.0ml/min
Temperature: ambient

Chromatographic column: Manufacturer A C18(250 mm*4.6mm* 5 μ m)
Mobile Phase: 0.05mol/L phosphate buffer(pH = 3.5)/MeOH/acetonitrile (50/35/15)
Flow rate: 1.0ml/min
Temperature: 40°C
Detection wavelength: 254nm
Injection volume: 20 μ L



Working Principle

L-3200 serial high pressure pump provides isocratic, binary and quaternary model base on request.

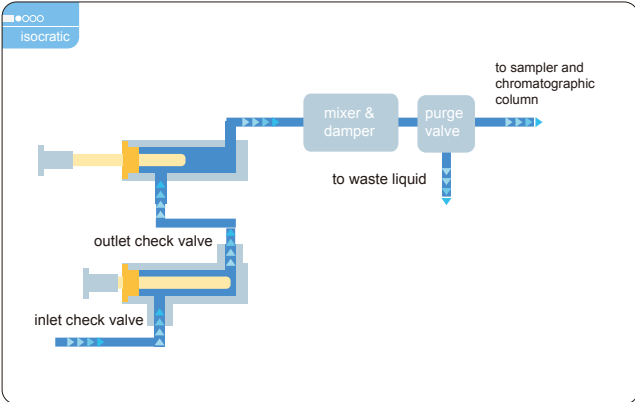

- Isocratic pump for regular QA/QC usage

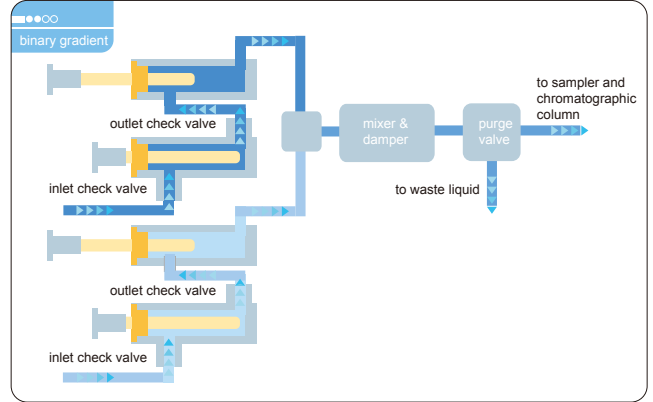

- Binary pump for high-throughput & fast analysis

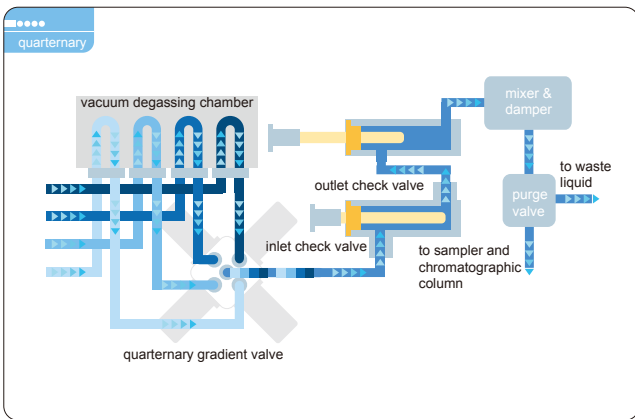

- Quaternary pump for pharmaceutical, food and environmental test.

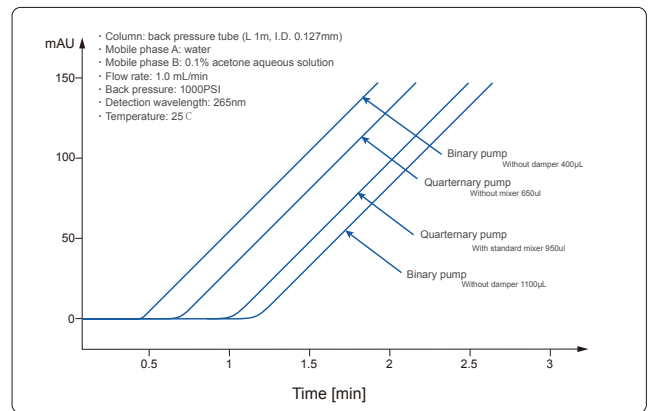

- Lower delay volume enables a cleaner & faster response to the gradient changes.

Special Design

Integrated Design

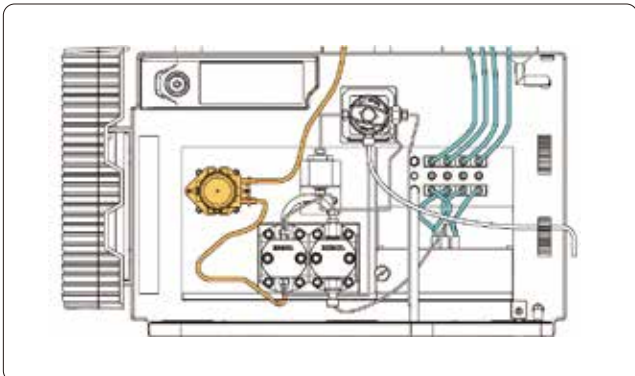

- L-3245 Quaternary gradient pump combine online degasser and seal wash function. This integrated design reduce delay volume, save bench space and simplify maintenance procedure.

Built-in Seal Wash Function

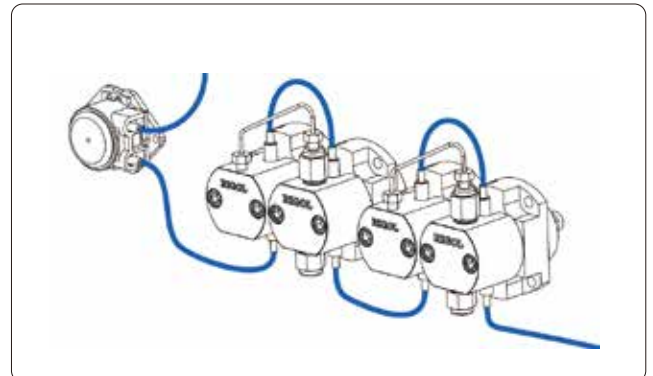

- Seal wash is a standard parts in L-3000 serial HPLC system. The part could flush the salt crystallization on the piston and extend the service life of sealing rings.

L-3320 Autosampler



Peak area %RSD

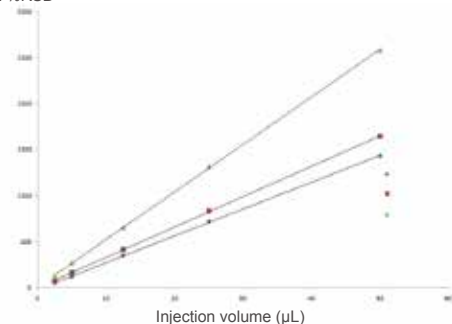

- Injection volume from 2.5 to 50µL, correlation coefficients of the 3 compounds are all 0.9999

Performance Highlights

High Precision

L-3320 autosampler delivers high injection precision of 0.3% RSD, thanks to its high precision machining parts and advanced control algorithm. It also employ a design of changeable sampling loop, which extend linearity range and meet the need of more applications.

Peak area %RSD

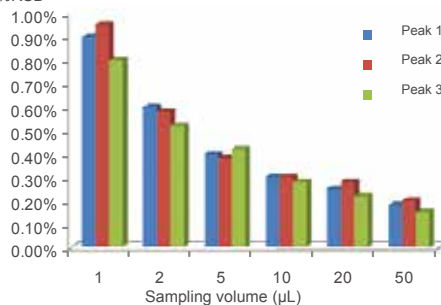

- Peak-area repeatability of 3 compounds with different sampling volume (RSD%)(n=6)

Low Cross Contamination

The special design of needle washing assembly could clean interior and outside of the sampling needle separately, combing the patented sampling needle design and extra precision inner and outer polishing technology, it could reduce the carryover of sample and avoid cross contamination.

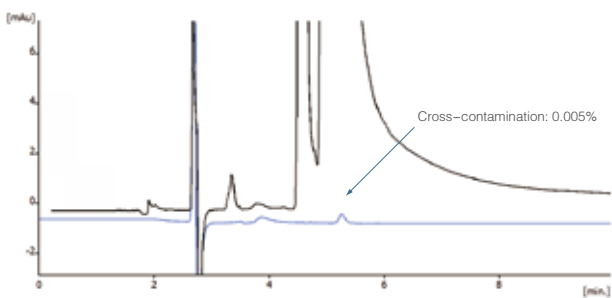

Chromatographic column: Rigol C18(250 mm x4.6mm x 5um)
Mobile phase: MeOH/Water(90/10)
Injection volume: 10µL
Cross-contamination: 0.005%(based on naphthalene-methanol solution)

Multi Injection Mode

L-3320 support three sampling mode including full loop, partial loop and micro pick-up injection for different requires. It could be easily choice in the method editor without hardware replacement.

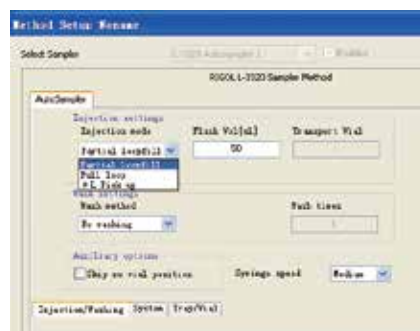

In the Method Setup interface

you can simply choose to click a different injection mode, then the replacement is completed.

Working Principle

Three Sampling Mode

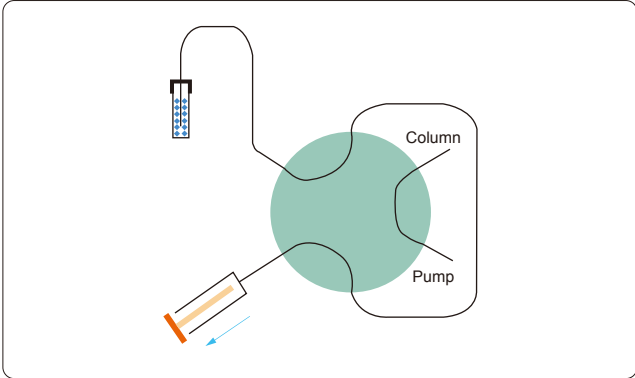

- L-3320 AutoSampler adopt suction sampling principle with simple & reliable structure to reduce delay volume, it divided into triple specific sampling modes.

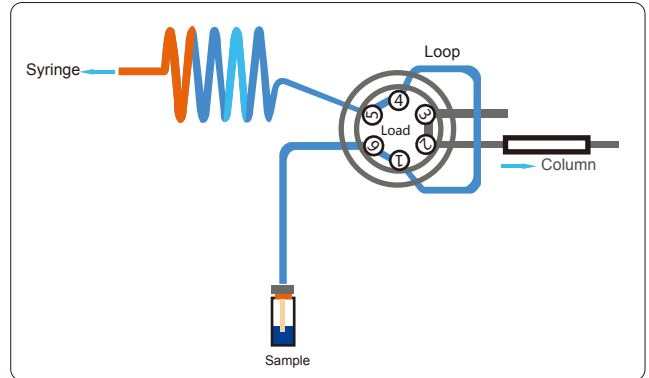

- Full loop injection possess best sampling precision, with the support of changeable sampling loop, this mode fulfill most requirements.

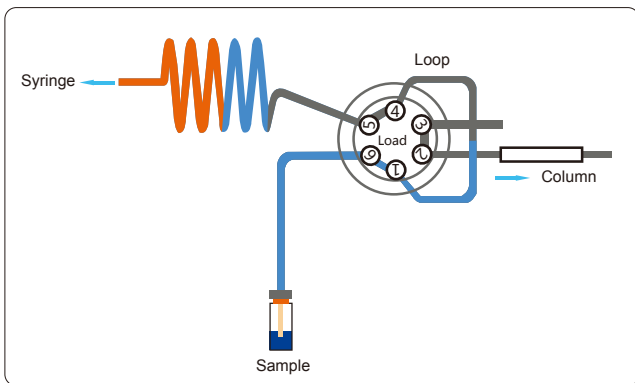

- Partial injection has the best and most flexible performance, you can set the injection volume to match the application.

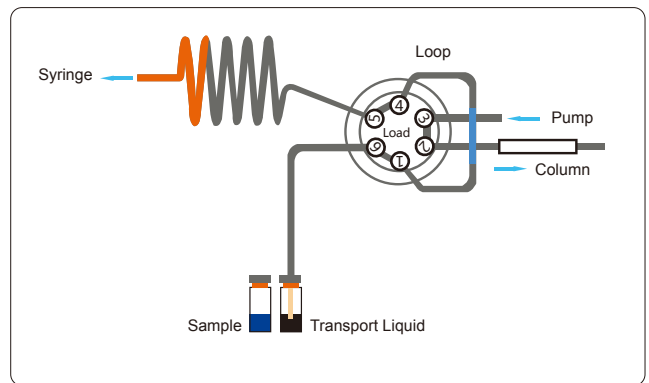

- Micro Pick-up mode was suitable for small quantity and precious sample, the injector will only pick up the setting volume sample and use the suitable

Special Design

Build-in Needle Wash Assembly

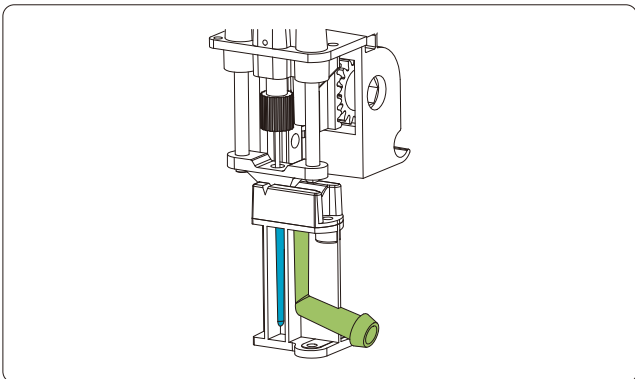

- The build-in needle wash assembly has two washing positions for inter and outer needle wash separately, this double wash mechanism reduced the carryover significantly.

Front Access to Maintenance Parts

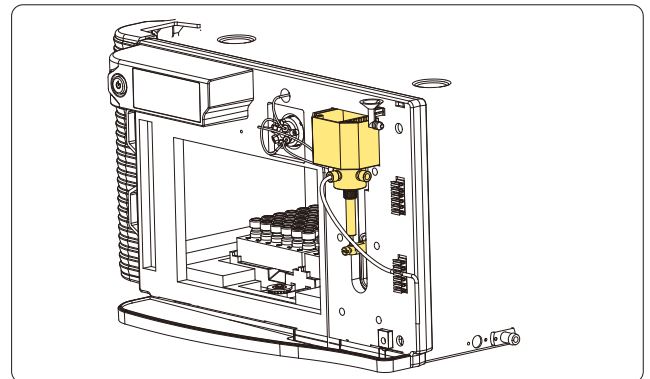

- All maintenance parts could be reached on the front side, which simplify the service procedure and lower maintenance cost.

L-3500

UV-VIS Detector



- Proprietary optical design for improved signal to noise ratio.

Wider Linearity Range

Adopt unique light path design, multi color optical filter and high quality grating, the detector realized much lower stray light, and extend the linearity range to 2.5AU.

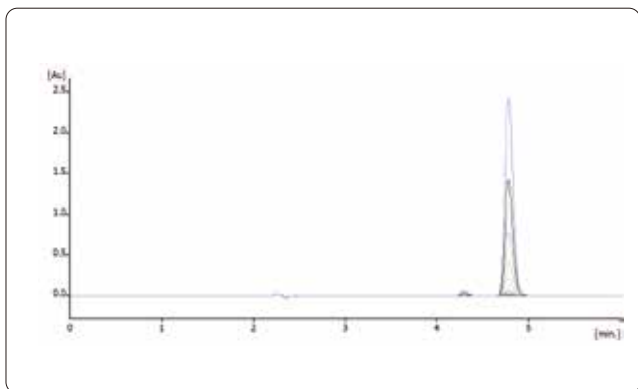

- The detector keeps excellent linearity up to 2.5 AU absorbance

Performance Highlights

High Sampling Rate

As support by unique high speed signal processing technology, L-3500 UV-VIS detector realized 100 Hz sampling rate, which make the detection of narrow peak with width lower than 5s possible. This high sampling rate also helps to record the chromatography peak accurately and get the best resolution.

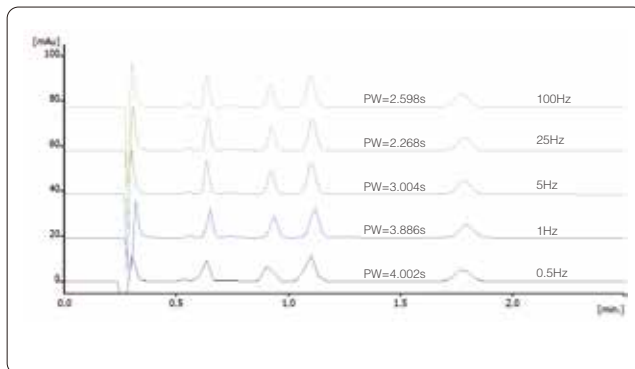

- 100Hz data sampling rate means that detection of peaks sharper than 5s wide is possible with excellent separation resolution.

Low Noise

L-3500 have a high performance SNR by the patent electric and structure design.

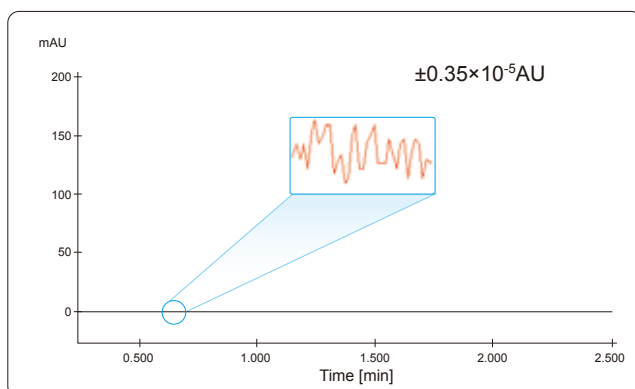

Working Principle

Dual Lamp Design

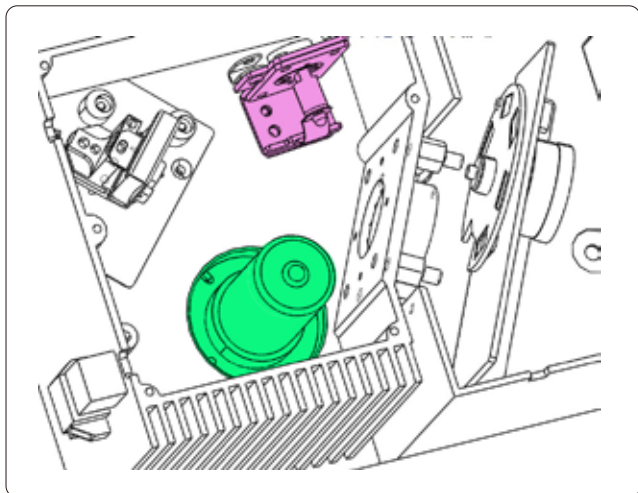

- L-3500 UV-VIS detector employ a dual lamp design, the deuterium & tungsten lamp enable the detector to cover both UV and visible range and fulfill the visible section detection and cover more application scope.

Easy Maintenance Flow Cell

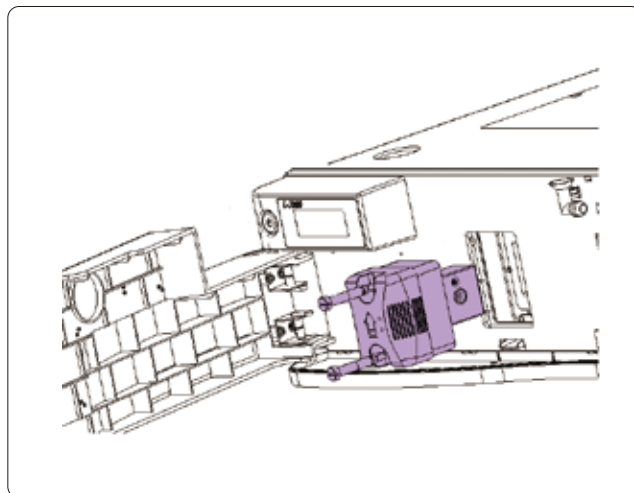

- The flow cell adopt modular design, it could be taken off by only 2 screws removing, very easy to maintenance.

Application Notes

L-3500 shows great stability, especially in those applications with long run time and low detecting wavelength, this advantage can be perfectly shown by the 120min run of Chinese medicine Ginseng.

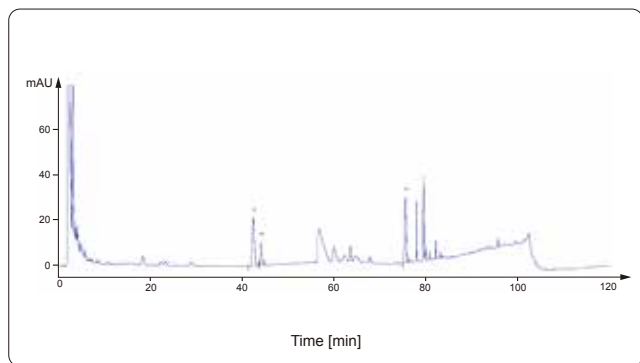

Chromatographic column: RIGOL Compass C18(250mm*4.6mm*5 μ m)
Mobile phase: water/acetonitrile; gradient elution
Flow rate: 1.0mL / min
Column temperature: 40°C
Detection wavelength: 203nm
Injection volume: 10 μ L

L-3500 can run wavelength program, which means switching detection wavelength during acquisition. This feature realized the programmable detection of several analytes with different chromophore.

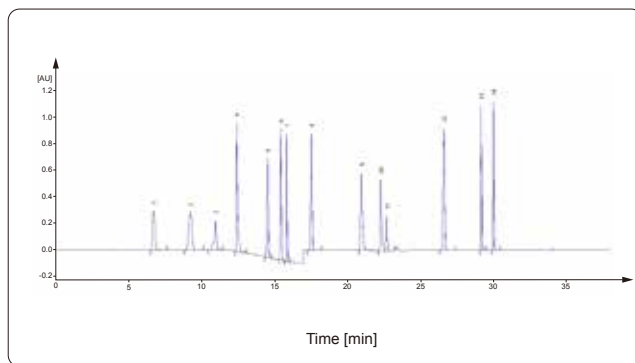

Chromatographic column: Manufacturer A C18(100 mm*4.6mm*2.7 μ m)
Mobile phase: 20mM aqueous ammonium acetate/acetonitrile; gradient elution
Flow rate: 1.0mL / min
Column temperature: 40°C
Detection wavelength: wavelength time program
Injection volume: 20 μ L

L-3520

Diode Array Detector

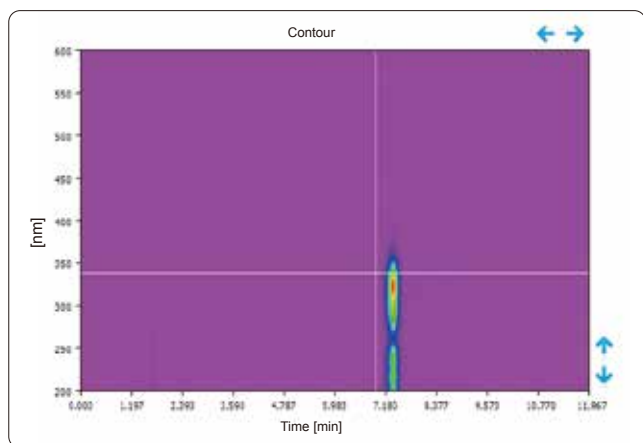

Performance Highlights

High Resolution Full Spectrum Scanning

L-3520 has a 1024 diode array sensor with pixel resolution of 0.6nm. Combine with high quality optical grating, it could record full high resolution spectrum while chromatogram recording.

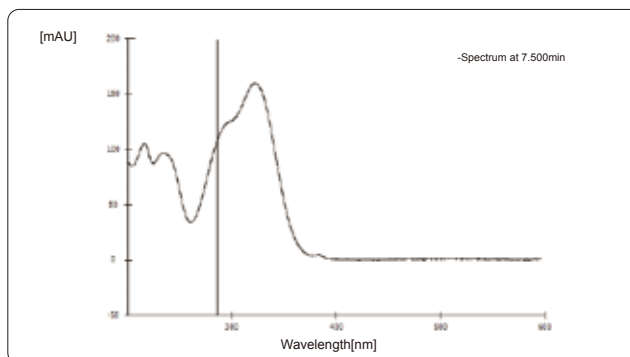
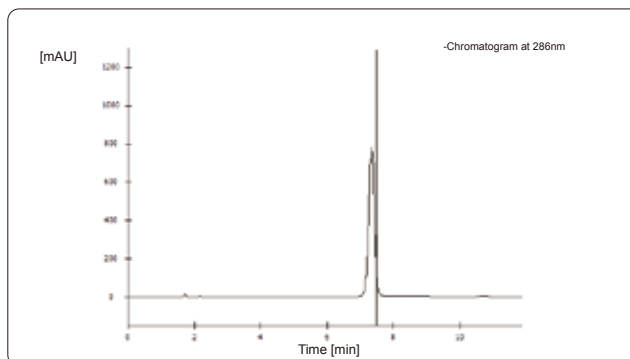

High Sensitivity

L-3520 realized $\pm 0.6 \times 10^{-5}$ AU noise level by its advanced optical and electric design, and gain much lower detection limit.

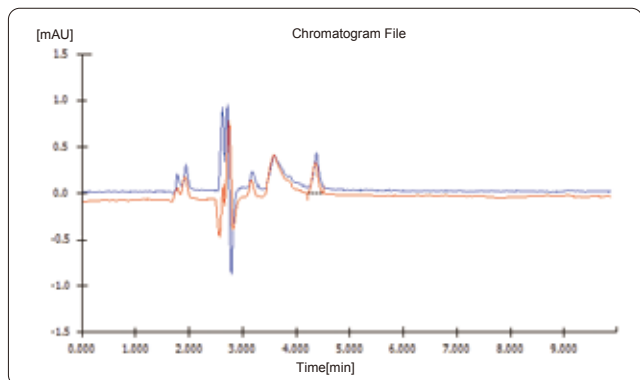

High Sampling Rate

RIGOL remains and advances the high sampling rate character of UV detector, and keep 100 Hz sampling rate with full spectrum scanning. Users can acquire high resolution spectrum, and also could extract chromatogram for quantitative analysis.

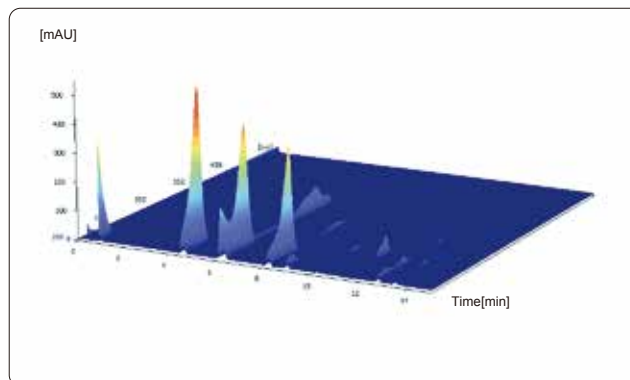

Working Principle

Easy Calibration Function

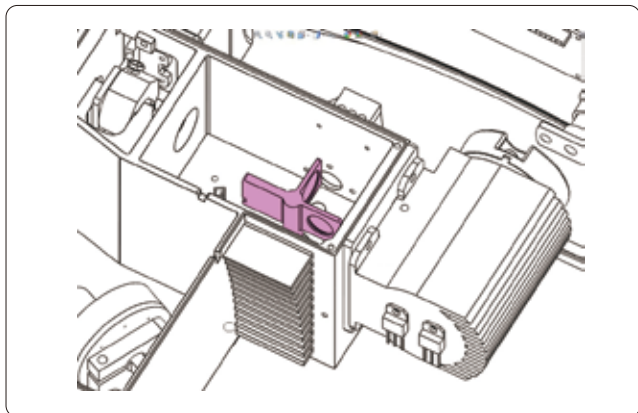

- L-3520 could realize full spectrum calibration by mercury lamp standard emission lines, and ensure the instrument stable and reliable by double inspecting the wave length accuracy via deuterium lamp characteristic peak and build-in holmium oxide filter.

Easy Accessed Lamp

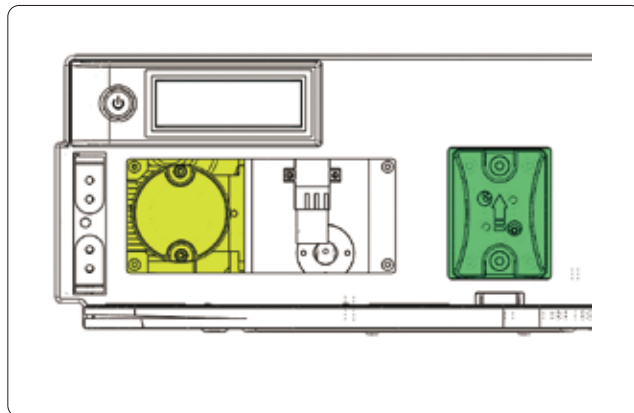

- L-3520 DAD adopt light prepositioning design, and equipped with easy disassembling flow cell. Client could do the lamp replacing independently and then reduce the future maintenance cost.

Applications

The chromophore of the eight phenols in olive oil varies a lot, those analytes must be monitored at different wavelength and the retention time is similar, those realities makes it impossible to analysis it by UV-VIS detector. DAD possess the ability of multi-wavelength detection and full spectrum acquisition, perfect for qualitative and quantitative analysis.

Chromatographic conditions

Chromatographic column: Manufacturer A C18(100mm*4.6mm*2.6 μ m)
Mobile phase: 0.2% aqueous phosphoric acid/acetonitrile; gradient elution
Flow rate: 1.0mL / min
Column temperature: 28 $^{\circ}$ C
Injection volume: 5 μ L

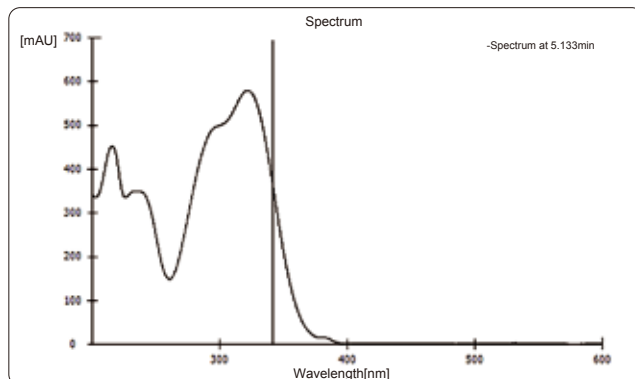
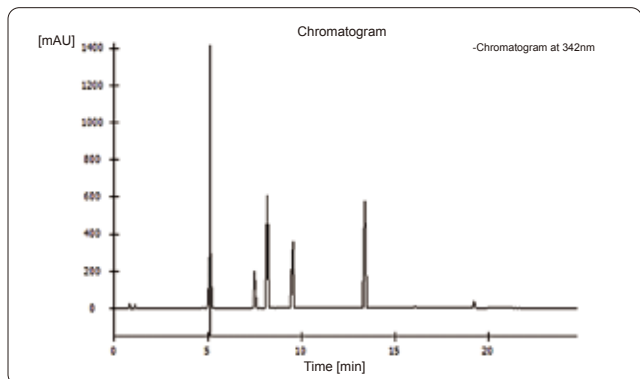
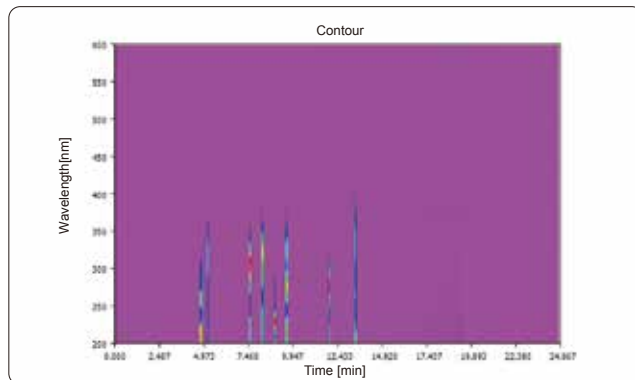
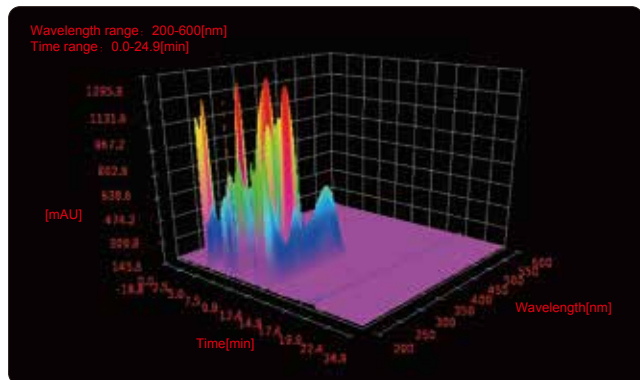

L-3535

Evaporative Light Scattering Detector



Performance Highlights

Low-Temperature Evaporation

SEDEX Automated Gain Adjustment (SAGA)

SAGA is an innovative gain control available when it is driver-controlled by software, SEDEX LC automatically adapts the gain setting to avoid any off-scale saturation of the detector.

Easy Maintenance

A single and dedicated SEDEX LC HPLC nebulizer and an innovative cell design minimize band broadening. This nebulizer covers the flow rate range from 100 μ L/min to 2.5mL/min and can be readily and quickly mounted and dismantled.

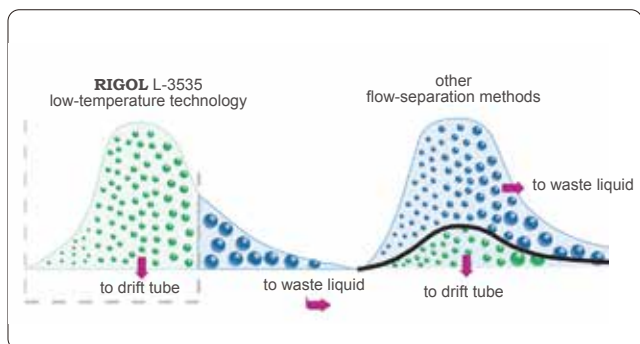

- With low-temp evaporation technology, the L-3535 can dramatically reduce baseline noise to improve sensitivity.

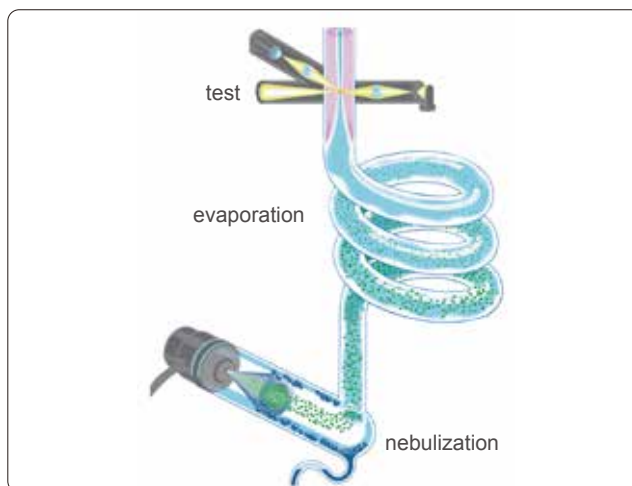

Applications

Determination of 15 underivatized amino-acids via HPLC-ELSD

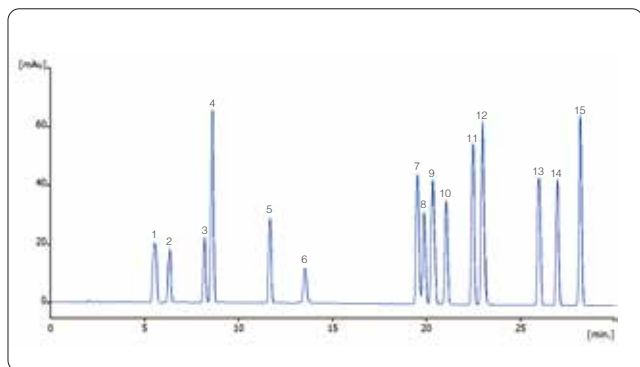

Chromatographic column: RIGOL AA(250 mm x4.6mm x 5 μ m)
Mobile phase: 0.2% Heptafluorobutyric Acid /MeOH; gradient elution
Temperature of drift-tube: 40 C
 Gain: 7

Determination of gentamycin sulfate injection via HPLC-ELSD

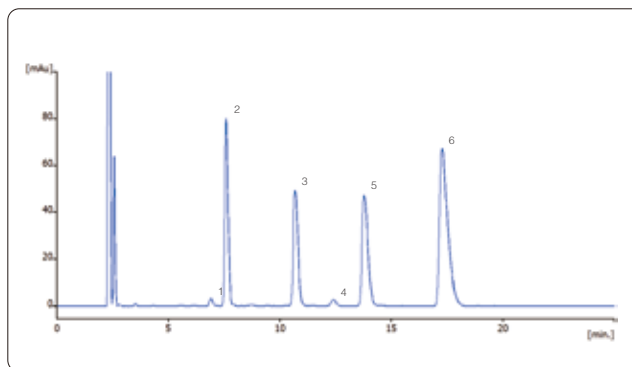

Chromatographic column: RIGOL AA(250 mm x4.6mm x 5 μ m)
Mobile phase: 0.2mol/L trifluoroacetic acid solution/MeOH (92/8)
Temperature of drift-tube: 50 C
 Gain: 6

L-3560

Refractive Index Detector



Performance Highlights

Broad Application

Detection is based on a universal property of all analytes and does not require the presence of a chromophoric group, electroactive group, etc.

Stable Performance

Base line will be rapidly balanced by the inner temperature control system. And prevent the influence due to the outside temperature floatation.

Easy Operation

Preposition operation panel will help you set the instrument in several steps, and no need to revise the parameter during the operation. This will reduce the learning cost and enhance the efficiency.

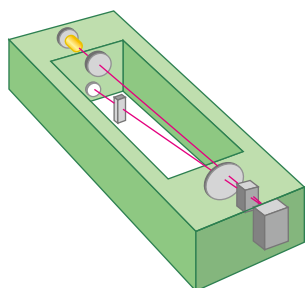

- L-3560 RID achieve better stability and repeatability by inner temperature control system.

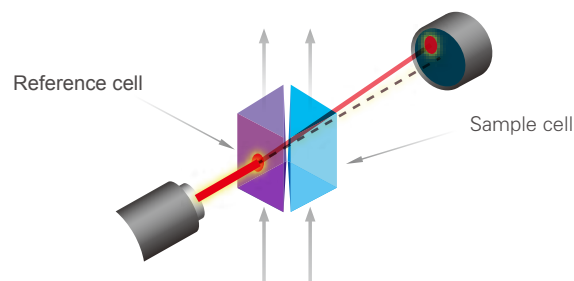

- L-3560 RID can detect all analytes that have different refractive coefficient in the mobile phase.

Applications

Analysis of Mannitol according to EP method

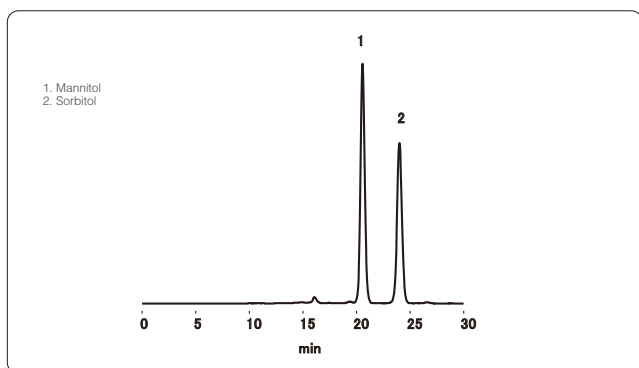

Chromatographic column: EP SC1011-7F (7.8mmI.D.x 300mm)
Mobile phase: Water
Flow rate: 0.5mL/min
Column temperature: 85 C

Analysis of Sugar and Furfural

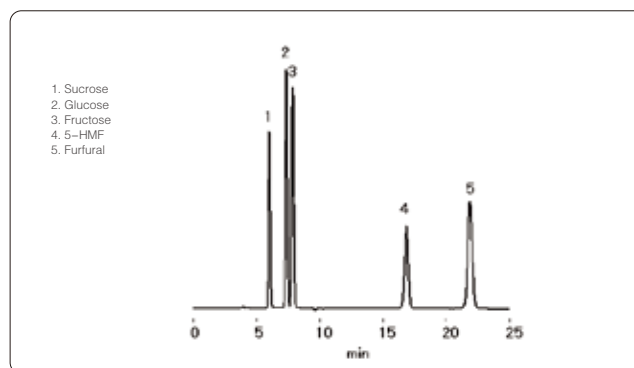

Chromatographic column: SUGAR KS-801 (8.0mmI.D.x 300mm)
Mobile phase: Water
Flow rate: 1.0mL/min
Column temperature: 80 C

L-3100 Series Solvent Organizer



Performance Highlights

Ultra Experience Operating

L-3000 HPLC system equipped with L-3100 serial solvent organizer, which could remove the bubble influence effectively, and reduce the pressure fluctuation & base line noise.

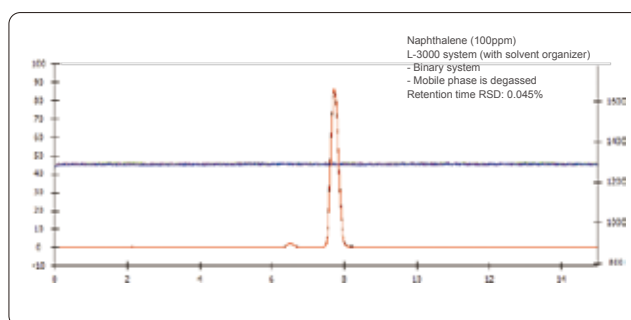
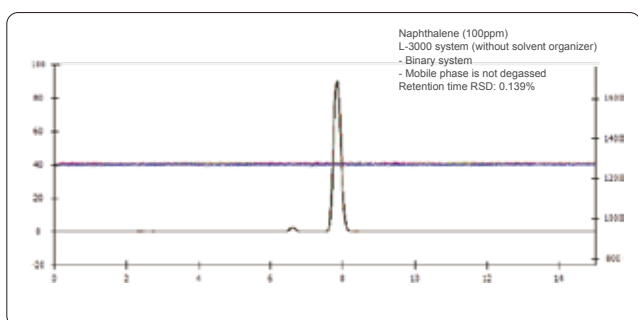

Pole Washing System

The washing system composed with solvent organizer and pump coordination, it could wash the pole and sealing ring salt crystallization and prolong the service life.

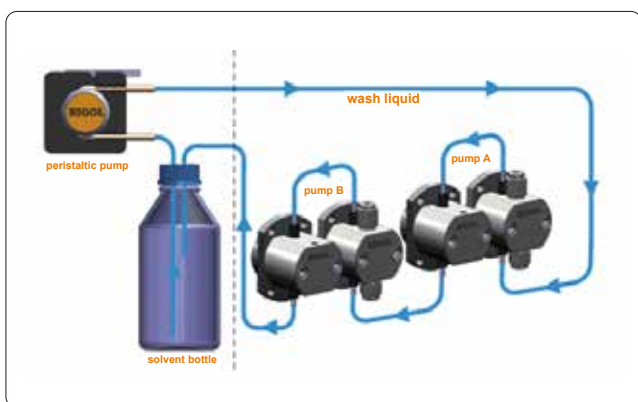

High Efficiency Degasser

L-3120 solvent organizer equipped with 2-Channel degasser which will remove the remaining gas dissolution in the mobile phase, and make the pump operation more stabilized and reduce the base line noise.

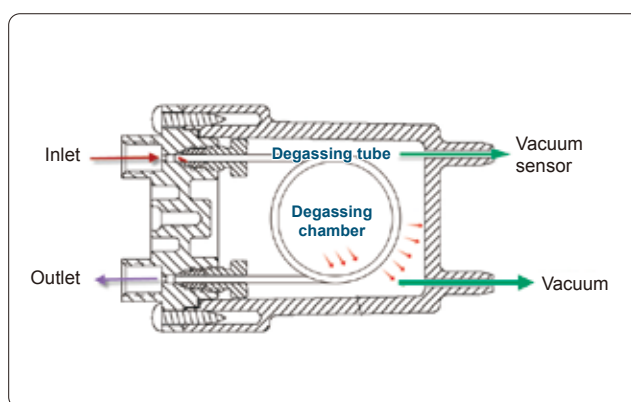

Bubbles Damages



- (1) It will lead to the big base line noise, and influence the base line till it could not be regularly works.
- (2) It might raise the problem with check valve, especially will cause big pressure floatation once you choose the pressure floatation control option.
- (3) Gradient mixing will generate the bubbles due to different characters of solvents. None degassing solvent provide the condition of bubbles generation.
- (4) Influence the detector operation, likes fluorescence quenching, reduce the sensitivity of FLD.

L-3400 Column Oven



Performance Highlights

Excellent Testing Results

L-3000 HPLC system work with L-3400 column oven, which could minimize the impact of environmental factors and then guarantee the superior results.

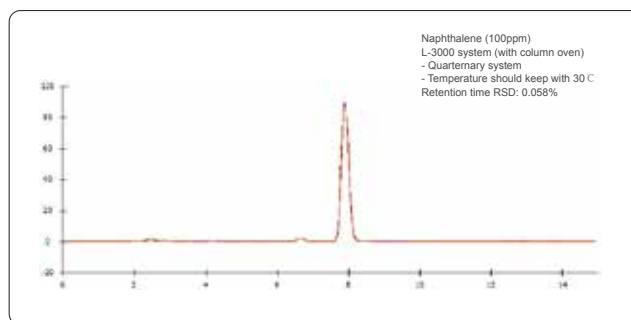
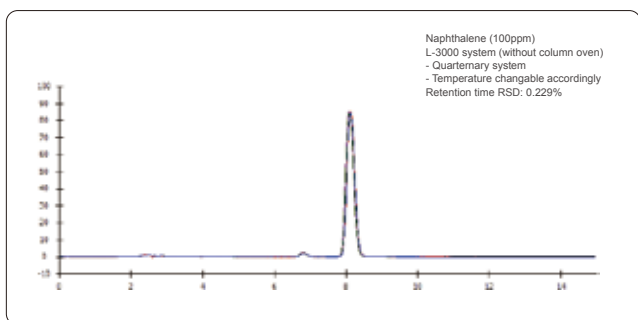

Preheating Function

Via preheating treatment, mobile phase will reach rated temperature before coming into the column, so avoid the unbalance temperature status in the column, then avoid the influence of temperature floatation also.

Precision Temperature Control

L-3400 utilized the semiconductor heating technology, and avoid the over shoot of temperature raising, then ensure the stable temperature raising and precision control.

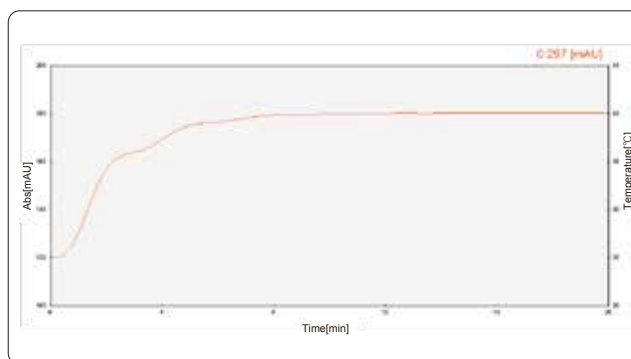
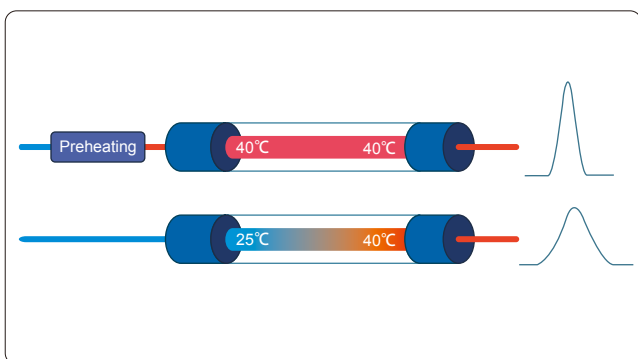

What is the semiconductor temperature control?

Utilized the Peltier reaction of semiconductor material, once the DC go through two different semiconductor material assembly couple, the couple will absorb and release the heat, so it could realize the cooling or heating target. The feature is, there is no any mobile parts and more reliable also.

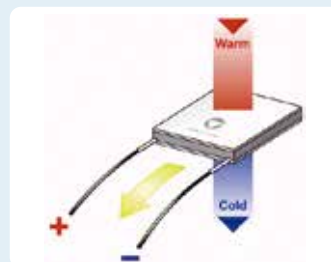

Clarity Chromatography Workstation

Clarity workstation furthers the capability of L-3000 series HPLC system with Analysis solution research and development, instrument control, data acquisition and processing, report generation, and traceable record management with versatile extensibilities.

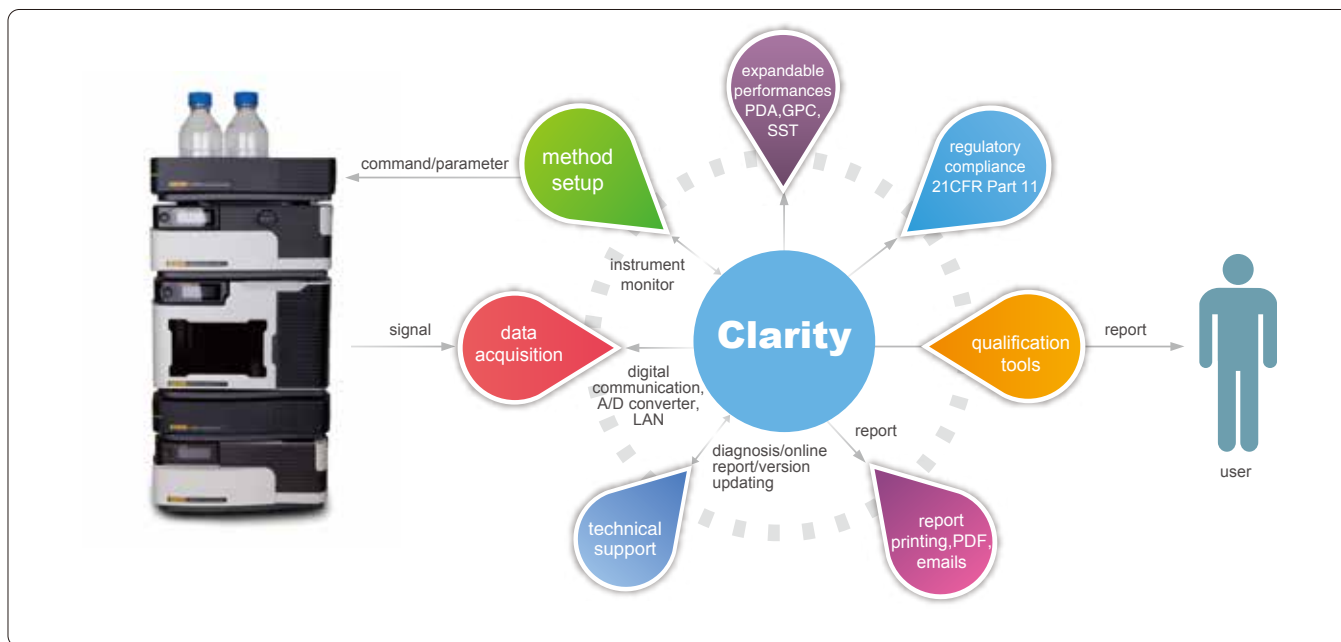

© Compliance with FDA 21 CFR Part 11/GMP/GLP

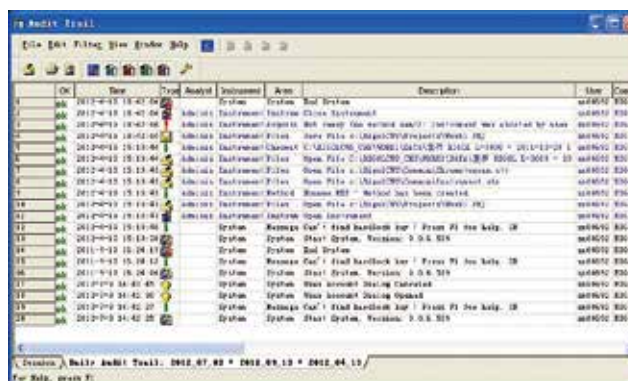



Direct instrument control plus intuitive user interface give user the simplicity of operating the instrument from software.

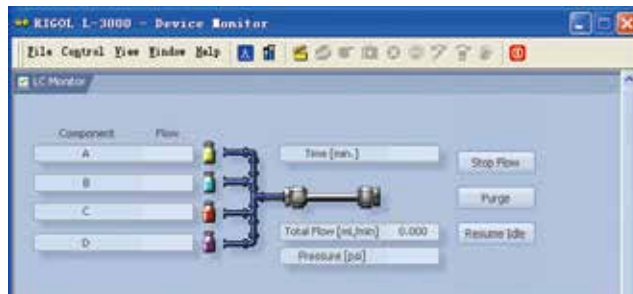

Simple method editing interface and powerful data processing with more than twenty integral functions.

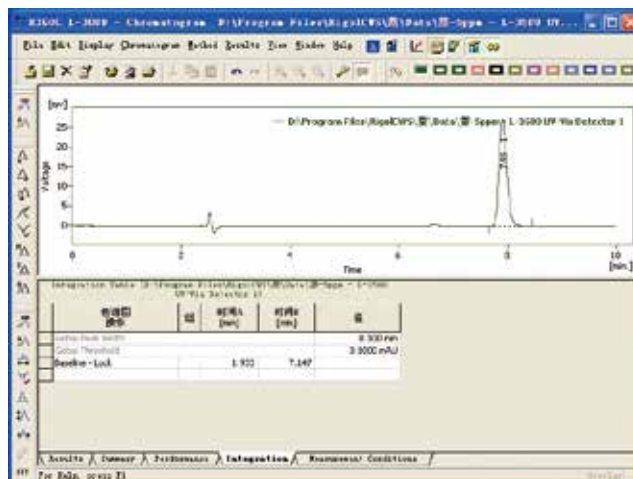
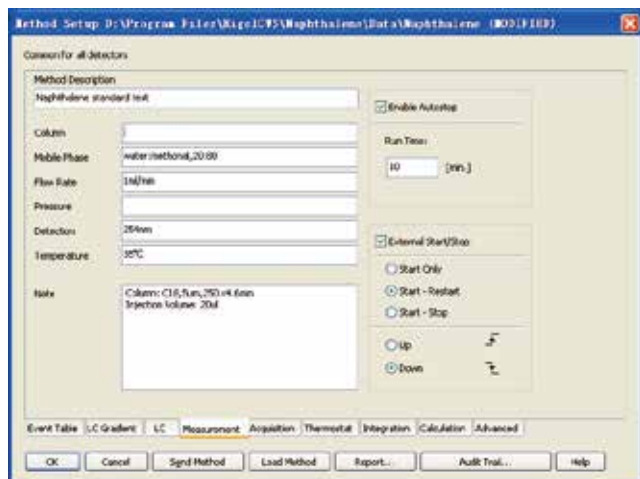

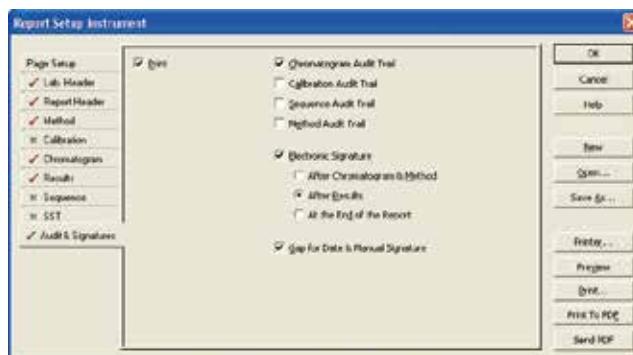
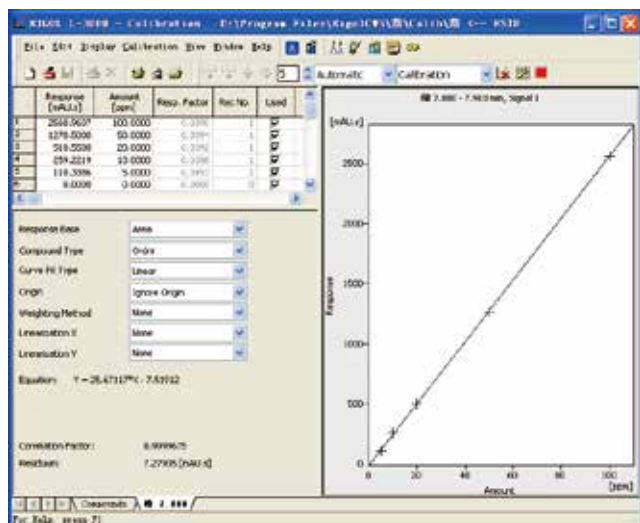

Various calibration procedures and customizable report editor.





Specifications

Solvent Organizer		L-3100 Solvent Organizer	L-3120 Solvent Organizer
	Online Wash	Standard Configuration	
	Online Degassing	None	2-channel (480 µL/channel)

Delivery Pump		L-3210 Isocratic pump	L-3220 Binary pump	L-3245 Quarternary pump
	Online Degassing	None	None	4-channel (480 µL/channel)
	Flow Rate Range	0.001 mL/min – 10.000 mL/min (increment 0.001 mL/min)		
	Flow Rate Accuracy	± 0.2%		
	Flow Rate Precision	≤ 0.1% (JJG) ≤ 0.06% RSD (ASTM)		
	Max. Pressure	9,000 psi		
	Pressure Pulsation	≤ 1% or < 10 psi		
	Gradient Accuracy	None	± 0.5%	
	Gradient Precision		± 0.1%	

Autosampler		L-3320 autosampler
	Sampling Mode	Full loop, partial loop and µL pick-up
	Volume of Sample Loop	standard: 100 µL (optional: 10 µL, 20 µL, 50 µL)
	Max. Sampling Volume	Full loop = loop volume Partial loop = 1/2 loop volume µL pick-up = (loop volume - 3 × needle volume)/2
	Sample Volume	2*48 1.5 mL vials (standard) (Optional: 96-hole well plate, 384-hole well plate)
	Cross Contamination	< 0.005%
	Linearity	0.9999
	Pressure Limit	6,000 psi (15,000psi sampling valve is optional)

Column Oven		L-3400 Column Oven
	Temperature Range	Room Temp +5 C - 70 C
	Temperature Accuracy	± 1.0 C
	Temperature Precision	± 0.1 C

ELSD		L-3535 Evaporative Light Scattering Detector
	Light Source	LED 470 nm
	Evaporation Temperature	RT - 100 C (increment 1 C)
	Flow Rate	0.1 mL/min – 2.5 mL/min (standard)
	Air Consumption	<3.0 L/min
	Air Required	>5 L/min nitrogen gas or air, 2 -4.5 Bar



UV-VIS Detector		L-3500 UV-VIS Detector
	Wavelength	190-800 nm
	Light Source	Deuterium lamp, Tungsten lamp
	Spectral Width	8 nm
	Wavelength Accuracy	± 1 nm
	Wavelength Precision	0.1 nm
	Noise	± 0.5×10 ⁻⁵ AU (JJG) ± 0.35×10 ⁻⁵ AU (ASTM)
	Drift	1×10 ⁻⁴ AU/Hr
	Linear Range	> 5×10 ⁴ (JJG) > 2.5AU (ASTM)
	Max. Sampling Rate	100 Hz
	Flowcell Pressure	1200 PSI
	Flowcell Light Path	10 mm
	Flowcell Volume	12 μL
	Detection Limit	4×10 ⁻⁹ g/mL (naphthalene)

Diode Array Detector		L-3520 Diode Array Detector
	Diode Array	1024 pixels
	Wavelength	190 ~ 640 nm
	Light Source	Deuterium lamp
	Spectral Resolution	0.6 nm/pixel
	Spectral Width	4.8 nm
	Wavelength Accuracy	± 1 nm
	Wavelength Precision	0.1 nm
	Noise	± 1.0×10 ⁻⁵ AU (JJG) ± 0.6×10 ⁻⁵ AU (ASTM)
	Drift	0.5×10 ⁻³ AU/Hr
	Linear Range	> 2.0 AU (ASTM)
	Max. Sampling Rate	12 channels, 100 Hz; Full spectrum, 100 Hz
	Flowcell Pressure	1200 PSI
	Flowcell Light Path	10 mm
	Flowcell Volume	12 μL
Detection Limit	2×10 ⁻⁸ g/mL (naphthalene)	
Wavelength Calibration	Mercury peaks and built-in holmium oxide filter	

Refractive Index Detector		L-3560 Refractive Index Detector
	Refractive Index range	1.00 ~ 1.75
	Measuring range	0.25 ~ 512 μ RIU
	Linearity range	≥600 μ RIU
	Response time	0.1, 0.25, 0.5, 1, 1.5, 2, 3, 6 sec
	Auto zero	Full auto zero
	Cell volume	8 μL
	Flow rate (Typical)	0.2 ~3.0 mL/min
	(Max.)	10 mL/min(solvent: pure water)
	Max. pressure	50 kpa
	Temp. control	OFF, 30 ~55 C (1 C step), 77 C Temp. fuse
Noise	≤2.5 nRIU (Pure water, response: 1.5 sec)	

Application and Solutions

Pharmaceutical Analysis

Determine the content of soybean isoflavones in Soybean Isoflavone Soft Capsule by RIGOL L-3000 HPLC system with core-shell column

Soybean isoflavones are a class of secondary metabolites formed in the growth of soybean. They are extracted from plant, similar structure with female hormone, so soybean isoflavones also called phytoestrogen. Soybean isoflavones can improve skin condition and osteoporosis, relieve the symptoms of menopause syndrome.

Chromatographic column: Manufacturer A C18(50mm*4.6mm*2.6μm)

Mobile phase: Phosphoric acid solution (pH=3.0)/Acetonitrile; gradient elution

Flow rate: 1.0mL/min

Column temperature: ambient

Detection wavelength: 260nm

Injection volume: 5μL

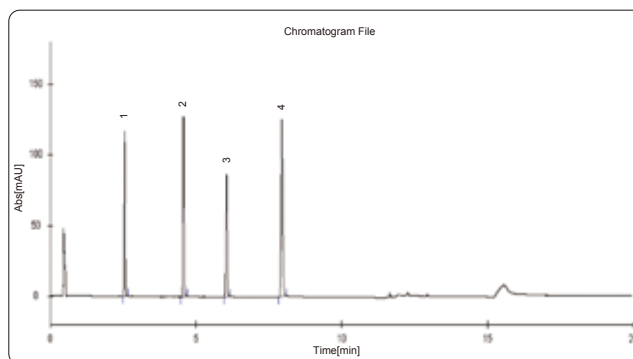

Environment Protection

Content determination of phenols compounds by HPLC

Phenols pollution in environment field means that phenols compounds pollute water. Waste water with phenols is one of the greatest dangerous, and most widely polluted industry waste water. In this paper, 9 phenols compounds were determined by using RIGOL L-3000 HPLC system. The results show that the method is accurate and sensitive.

Chromatographic column: RIGOL compass C18(250mm*4.6mm*5μm)

Mobile phase: Water/Acetonitrile; gradient elution

Flow rate: 1.0mL/min

Column temperature: 40 C

Detection wavelength: 223nm

Injection volume: 5μL

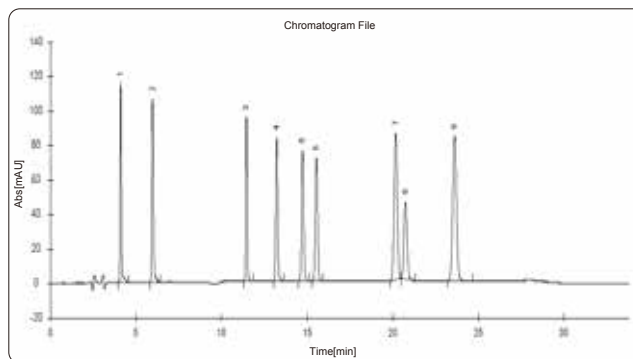

Food Safty

Simultaneously determining the content of 8 kinds of organic acids and Vitamins in fruit by using HPLC-DAD

Organic acids and vitamins are very important dry matter in fruits. They usually decide the special taste of fruits and play an important role in food science and nutriology field. In this paper, the new method can simultaneously determine organic acids and vitamins in fruits by using HPLC-DAD.

Chromatographic column: RIGOL Compass C18(2) (250mm*4.6mm*5μm)

Mobile phase: Water/Acetonitrile; gradient elution

Flow rate: 0.6mL/min

Column temperature: 30 C

Injection volume: 10μL

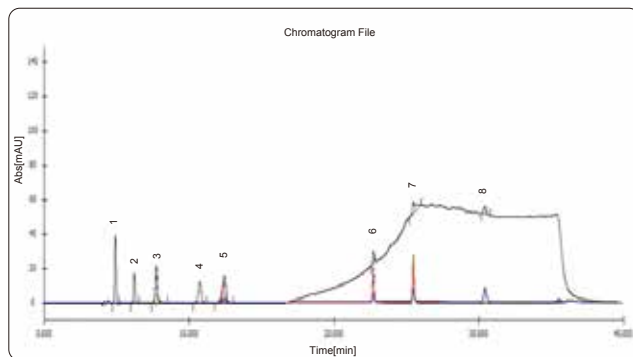

Agriculture

Simultaneously determining the content of 4 kinds of sulfa-drugs in fodder by using HPLC-DAD

Sulfa-drugs are a class of chemical medicine for disease prevention and treatment of bacterial infections. If take sulfa-drugs standard exceeding livestock products as food for a long time, it might lead to the damage of hematopoietic system, agranulocytosis and so on problems. So that the application limit of sulfonamides in livestock and poultry raise up and play an important role in food safety field. In this paper, an accurate and sensitive method was established to determine the content of 4 kinds of sulfa-drugs in feed by using HPLC-DAD.

Chromatographic column: RIGOL Compass C18(250mm*4.6mm*5 μ m)

Mobile phase: Water/Acetonitrile (75/25)

Flow rate: 1.0mL/min

Column temperature: 40C

Injection volume: 5 μ L

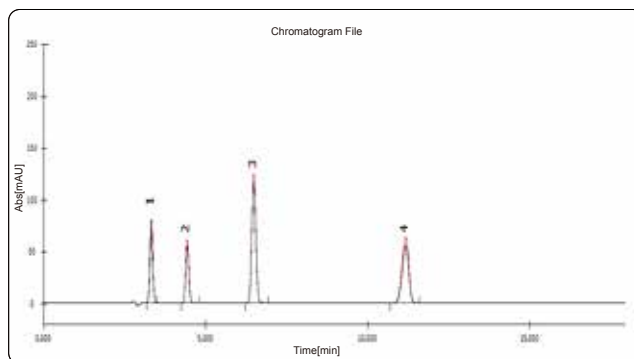

Chemical

Simultaneously determining the content of 6 kinds of UV absorbers in cosmetics

UV absorbers in cosmetics can reduce or absorb the ultraviolet rays, protect skin. Excess ultraviolet radiation will irritate skin and cause skin sensibility. The application of UV absorbers is managed and controlled strictly. In this paper, a new method is developed to determining the content of 6 kinds of UV absorbers in cosmetics.

Chromatographic column: Manufacturer A C18(250mm*4.6mm*5 μ m)

Mobile phase: A: MeOH/Tetramethylene oxide (250/450);

B: Water/Perchloric acid (300/0.1); gradient elution

Flow rate: 1.0mL/min

Column temperature: 30C

Detection wavelength: 311nm

Injection volume: 10 μ L

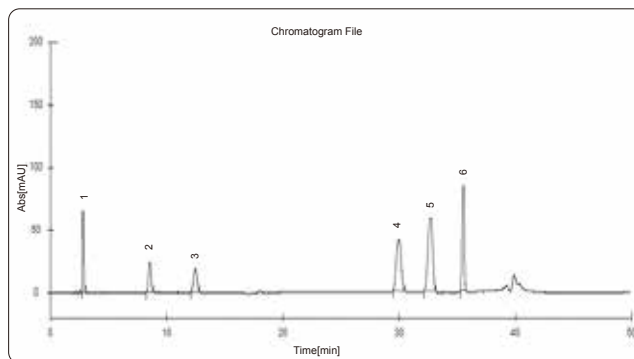

Antibiotics

Determining the content of terramycin, doxycycline, tetracycline and auromycin by HPLC

In the livestock farming field, all kinds of antibiotics are used for treatment of livestock disease. Tetracycline antibiotics are widely adopt based on its antibacterial effect and cheap price. Tetracycline antibiotics mainly include terramycin, doxycycline, tetracycline and auromycin.

Chromatographic column: Manufacturer A C18(250mm*4.6mm*5 μ m)

Mobile phase: MeOH/Acetonitrile/0.01mol/L Citric acid solution (12/18/70)

Flow rate: 0.8mL/min

Column temperature: 30C

Detection wavelength: 360nm

Injection volume: 50 μ L

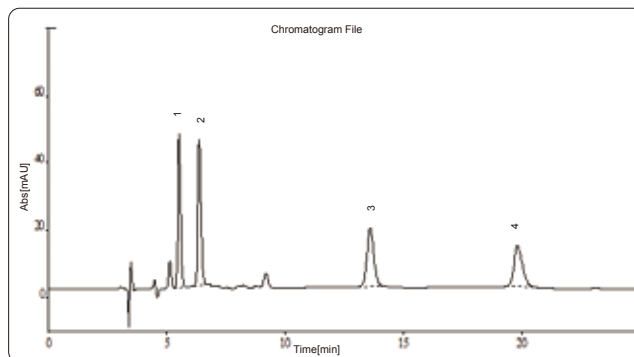

Customer Service

01. Installation >>>>

RIGOL provide installation service with instrument working principle introduction, standard operation procedures, daily maintenance and application developing.

02. After Sale Service >>>>

RIGOL has a professional service team, and build up the maintenance record via the clients information system, we also arrange periodicity visiting service and preventive suggestion.

03. Regulation Compliance >>>>

RIGOL provide the compliance service for HPLC system, including the IO, OQ, PQ and so on. We can also provide the related training course to match up with the inspection request.

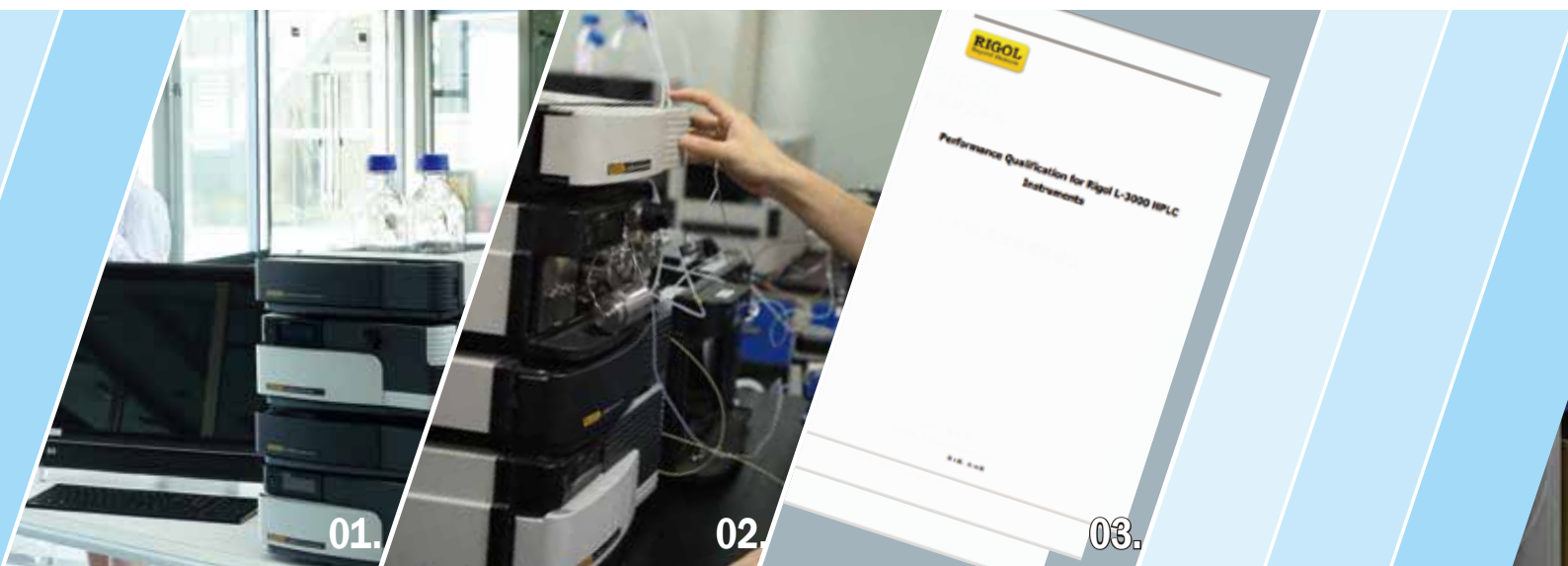



Professional services

04. Application Support >>>>>

A cross-field application team covering pharmaceutical analysis, food safety, Bioscience and environment field is ready to support. They are focus on solving the application problem raised from client, and will provide the integrated solutions.

05. Multiple Training >>>>>

RIGOL provide abundant online and offline standard training course. And could provide pertinence training course with client application and will enhance the skill of client.

06. Comprehensive Service >>>>>

RIGOL provide 360 degree, proactive service support. Our technical team would like to provide you the technical and maintenance support with fast reaction and reasonable suggestion. Field service engineer team is ready at any time for emergency issues.



Headquarter

RIGOL SCIENTIFIC, INC.

Address: No.156, Cai He Village, Sha He Town, Chang Ping District, Beijing

Postcode: 102206 P.R.China

Tel: +86-10-80706688

Fax: +86-10-80706688-668

EUROPE

Lindbergh str. 4

82178 Puchheim

Germany

Email: info-europe@rigoltech.com

USA

10200 SW Allen Blvd, Suite C

Beaverton, OR 97005, USA

Email: info@rigol.com

Japan

Tonematsu Bldg. 5F, 2-33-8 Nihonbashi-Ningyocho,

Chuo-ku,

Tokyo 103-0013 Japan

Email: info-japan@rigol.com

India

L-143, Sector 10, Jeevan Bima Nagar Bangalore

- 560 075 India

Email: info-india@rigol.com

Service & Support Email Address: service.chem@rigol.com

RIGOL® is the registered trademark of **RIGOL** Scientific, Inc. Product information in this catalogue subject to be changed without notification. For the latest information about **RIGOL**'s products, applications and services, please contact **RIGOL** local office or visit hplc.rigol.com