



Setting New Standards in Laboratory & Industrial Weighing— The Next Generation of Scout Balances

Ideal for laboratory & industrial applications, the OHAUS Scout features an easy to navigate color touchscreen display & a slim design which allows stackable storage. Geared for superior performance with fast stabilization time and high resolution weighing results, these portable balances set a new standard for a broad range of weighing applications. Features also include superior overload protection and expanded connectivity options.

Standard Features Include:

- **Quick and Efficient Navigation with the Informative Color Touchscreen Display**
Large, resilient color touchscreen allows for effortless operation of the Scout through its informative icon driven menu structure, guiding the user through every step of the weighing application.
- **Fast Weighing Speed and High Resolution Deliver Repeatable and Reliable Results**
Stabilization time as fast as 1 second means increased productivity in your facility. Equipped with advanced weighing technology, the Scout also ensures repeatable and reliable weighing results.
- **Superior Overload Protection & Stackable Storage Drive Overall Durability**
Integrated superior overload protection system rated at 10 times the capacity protects the balance in rugged and demanding environments. The space-saving, slim design allows for stackable storage.
- **Multiple Weighing Modes and Languages for Simplified Weighing**
The Scout offers multiple built-in application modes, making even the most complex weighing tasks easy to perform. With 9 language options, users can even operate the scale in their own language.

Scout® Portable Precision Balances

Navigate and Operate the Balance Easily with the Informative Touchscreen Display

Portable balance operation has never been easier, faster or as intuitive as the OHAUS Scout with color touchscreen display. You'll navigate easily through the Scout's resistive touchscreen interface and icon-driven menu structure, maneuver efficiently in and out of application modes, change weighing units with a simple tap on the screen and execute setup and calibration functions in no time. The OHAUS Scout with color touchscreen display creates a new level of unmatched efficiency and functionality in portable weighing.

A real-time clock function keeps accurate time even during power loss. Additionally, GLP/GMP tracking capabilities assist in the monitoring and reporting of data.

Increased Efficiency and Productivity in your Facility

It's all about accuracy and efficiency with the OHAUS Scout Touchscreen balance. Stabilization time as fast as 1 second means increased productivity in the lab, or on the line. With improved resolution, you can count on extremely precise and repeatable weighing results time and time again.

Scout's Signature Durability Remains Unrivaled

You would expect nothing less from OHAUS than the most durable portable weighing product—that's why we've included our superior overload protection rated at 10 times the capacity of the balance, high strength stainless steel pan, impact-resistant pan support and integrated transportation/storage lock. We've even ensured that the high quality, resistive touchscreen is built to last. To complement our signature durability, the Scout Touchscreen is designed to be stackable when utilizing the included stacking and storage cover, which also protects the balance when not in use.

Expanded Connectivity Options for Versatile Data Collection and Transfer

Scout offers 9 application modes which address even the most complex of weighing applications.

Users also have the option of operating the balance in their own language. 9 language options are available—English, Spanish, German, Italian, French, Polish, Hungarian, Czech and Turkish.

Draftshield Model Available

Scout's ingenious draftshield (1mg models only) was designed with an easy to remove top cover piece. This serves as a wind protection ring which keeps the weighing surface stable in rough environments, while maintaining weighing speed.





Draftshield

Protects the sample from external influences, increasing the speed and repeatability of measurements



Connectivity

Expanded connectivity options including RS232, USB Host, USB Device, Ethernet and Bluetooth®



Security Slot

Integrated security slot prevents theft



Weigh Below Hook

The integral weigh below hook on the bottom of the Scout allows for density determination or specific gravity calculations



Color Touch Screen Display

Informative icon-driven touchscreen display for easy navigation



Lockswitch

The Scout can be locked into a specific configuration using the lockswitch

Built-in Application Modes:

- **Weighing**—Determines the weight of items on the pan in the selected unit of measure.
- **Parts Counting**—Counts the number of pieces on the pan using a uniform weight.
- **Percent Weighing**—Measures the weight of a sample displayed as a percentage of a pre-established reference weight.
- **Check Weighing**—Compares the weight of a sample against target limits.
- **Dynamic Weighing**—Weighs an unstable sample load. The balance takes an average of weights over a period of time.
- **Totalization**—Measures cumulative weight of multiple items. Cumulative total may exceed balance capacity.
- **Density Determination**—Determines density of solids or liquid. With the integrated weigh below hook, it is possible to perform specific gravity tests for objects that cannot be easily placed on the weighing pan.
- **Display Hold**—Manually holds the last stable weight or the first highest stable weighing value on the display.
- **Mole Weighing**—Measures the weight of a sample and calculate it into Moles automatically.

Outline Dimensions

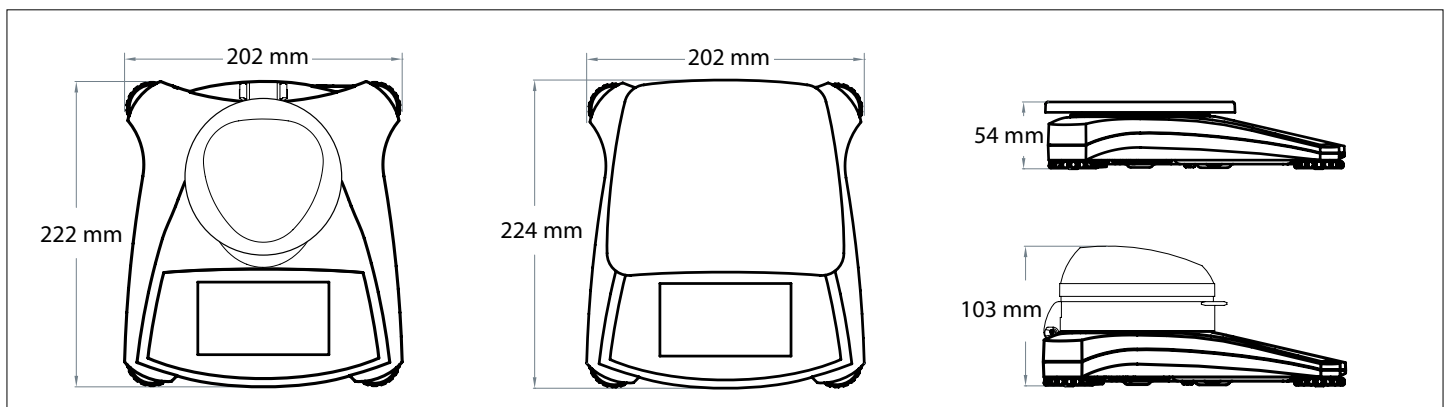

Scout® Portable Precision Balances

Model	STX123	STX223	STX222	STX422	STX622	STX1202	STX2202	STX421	STX621	STX2201	STX6201	STX8200
Capacity (g)	120	220		420	620	1200	2200	420	620	2200	6200	8200
Readability (g)	0.001		0.01				0.1				1	
Repeatability (Std. Dev.) (g)	0.002		0.01		0.02		0.1				1	
Linearity (g)	0.003		0.01		0.02	0.03		0.1		0.2	1	
Span Calibration Mass ¹	100 g	200 g		300 g		1 kg	2 kg	200 g	300 g	2 kg	5 kg	8 kg
Linearity Calibration Mass	50, 100 g	100, 200 g		200, 400 g	300, 600 g	500 g, 1 kg	1 kg, 2 kg	200, 400 g	300, 600 g	1 kg, 2 kg	3 kg, 6 kg	4 kg, 8 kg
Stabilization Time (s)	1.5		1		1.5		1					
Construction	ABS housing & stainless steel pan											
Draftshield	Yes		No									
Calibration	User-selectable external span or linearity calibration/Digital with external weight											
Tare Range	Full capacity by subtraction											
Weighing Units ²	mg, g, kg, ct, N, oz, ozt, dwt, lb, lb:oz, grn, custom unit											
Application Modes	Weighing, Parts Counting, Percent Weighing, Check Weighing, Animal/Dynamic Weighing, Totalization, Density Determination, Display Hold, Mole Weighing											
Power Requirement	AC adapter (included) or 4 AA batteries (not included)											
Typical Battery Life	6 hours											
Communication	RS232, USB Host, USB Device, Ethernet or Bluetooth® (available as an accessory, compatible only with Android OS device)											
Display Type	109 mm full-color VGA graphic touchscreen display with user-controlled brightness											
Display Size	109 mm (diagonal)											
Overload Capacity	10 times the rated capacity											
Operating Temperature Range	10°C to 40°C at 10% to 80% relative humidity, non-condensing											
Storage Conditions	-20°C to 55°C at 10% to 90% relative humidity, non-condensing											
Pan Size (W × D)	Ø 93 mm		Ø 120 mm		170 × 140 mm		Ø 120 mm		170 × 140 mm			
Balance Dimensions (W × D × H)	202 × 222 × 103 mm		202 × 224 × 54 mm									
Shipping Dimensions (W × D × H)	300 × 250 × 129 mm											
Net Weight	1 kg											
Shipping Weight	1.6 kg											

¹ Span calibration weight is included with models up to 620g capacity

² Availability is dependent on model and region

Other Standard Features and Equipment

Transportation lock, stainless steel pan, menu & calibration lockout switch, slip-resistant and adjustable feet, leveling bubble, mechanical and software overload/underload protection, stability indicator, auto tare, low battery indicator, auto shut-off, user-selectable printing options, user-selectable communication settings

Compliance

- **Product Safety:** IEC/EN 61010-1; CAN/CSA C22.2 No. 61010-1; UL Std. No. 61010-1
- **Electromagnetic Compatibility:** IEC/EN 61326-1 Class B; FCC Part 15 Class B; Industry Canada ICES-003 Class B

Accessories

RS232 Interface Kit30268982
 USB Host Interface Kit30268983
 USB Device Interface Kit.....30268984
 Bluetooth Interface Kit30268985
 Ethernet Interface Kit.....30268986
 Stacking & Storage Cover (6 pcs).....30268987
 Stacking & Storage Cover (1 pc).....30268988

Printer, Impact, SF40A, EU30064202
 Auxiliary Display Kit.....30269019
 Security Device.....80850043
 Top Loading Kit for Density Determination
30269020
 Carrying Case30269021
 In-use Cover.....30269022

OHAUS Europe GmbH
 Im Langacher 44
 8606 Greifensee
 Switzerland

e-mail: ssc@ohaus.com
 Tel: 0041 22 567 53 19
 e-mail: tsc@ohaus.com
 Tel: 0041 22 567 53 20

www.ohaus.com

OHAUS Corporation is an ISO
 9001:2008 manufacturer

ISO 9001:2008
 Registered Quality
 Management System

CH16B175

